

(GST DRILL RIG)

(DIMENSIONS)

- *Weight of unit: 6378 kg
- *Length of carrier: 2.9m
- *Max operating height: 4.0m
- *Boom Length (when retracted): 4.0m
- *Boom length (when extended): 6.0m
- *Feed rail length: 2.85m
- *Hole-length: 2.2m

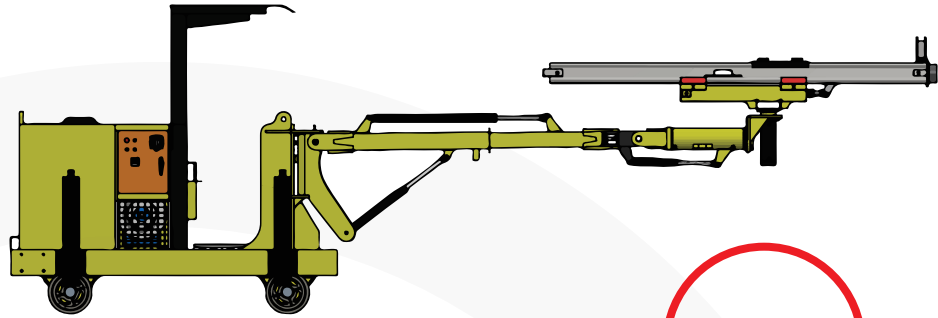

4 Meters

Operating Height

(CAPACITIES)

- *Feed pressure (Hydraulic drifter): 180kg/25 mm²
- *Power source: 2 x 30 kW / 4 pole | 525V electric motor | 65cc Displacement | Piston Pump | 2 x 24cc Gear Pump | 2 x 10cc Gear Pump
- *Hydraulic oil (Tank capacity): 2 x 172 litres
- *Mode: HC25
- *Shank: R32 Female

50 Hz

Impact Rate

(PERFORMANCE)

- *Percussion pressure: 140 bar
- *Percussion flow: 60 - 65 l/min
- *Rotation pressure: 140 bar
- *Rotation flow: 20l/min
- *Impact power: 9 Kw
- *Oil flow range: 60-75 l.p.m.
- *Impact rate: 50 Hz
- *Rotation speed: 50 - 300
- *Max rotation torque: 150 Nm
- *Water consumption: 30 l/mn
- *Bit size: 344mm - 55mm

150 Nm

Max Rotation Torque

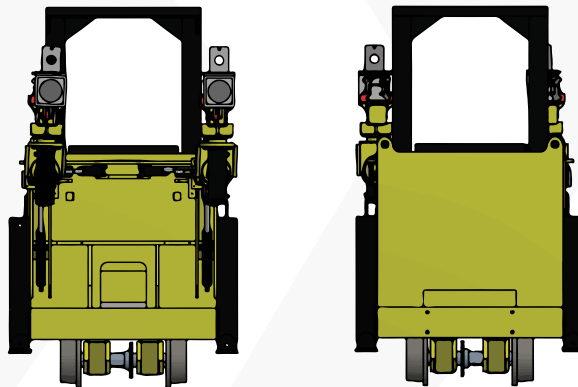

180KG/25mm²

Feed Pressure

