

(Unit M100HF)

(PERFORMANCE)

- LOADING CAPACITY KG 1075-1450*
- OPERATING WEIGHT KG 3540-3840*
- TIPPING LOAD KG 2400
- BREAKOUT FORCE KG 3500
- SPEED km/hr 0 - 12
- DOUBLE SPEED km/hr 9-18

(ENGINE)

- ENGINE- (STANDARD) KUBOTA V3800-DI-TE
- ENGINE POWER- 100HP-72,8kW @ 2600RPM
- FUEL TYPE- DIESEL
- DISPLACEMENT- cm³ 3769
- CYLINDERS - 4
- COOLING SYSTEM-LIQUID

(HYDRAULIC SYSTEM (REXROTH BOSCH))

- DRIVE PUMPS-Tandem Pump 320 bar
- BOOM AND BUCKET PUMPS-32 cc 220 bar
- ATTACHMENT PUMP-160 lt/min 300 bar
- HYDRAULIC FLOW-L /min 161
- PRESSURE BAR-300
- OPERATION-JOYSTICK
- BRAKES-HYDROSTATIC BRAKE SYSTEM

(CAPACITIES)

- FUEL TANK-lt 90
- HYDRAULIC OIL-lt 180
- ENGINE OIL-lt 11
- ELECTRIC SYSTEM BATTERY-12V - 105A
- NO ELECTRONIC COMPONENTS

(TIRES)

- TIRES-12 x 16,5 STANDARD

(DIMENSIONS)

- WIDTH OVER BUCKET 1860 mm
- WIDTH OVER CHASSIS 1360 mm
- LENGTH WITH BUCKET 3780 mm MAX.
- DUMP HEIGHT 2425 mm
- HINGE PIN HEIGHT AT MAX.
- LIFT 3122 mm MAX.
- HEIGHT 3998 mm
- HEIGHT TO TOP OF CAB 2070 mm
- GROUND CLEARANCE 225 mm

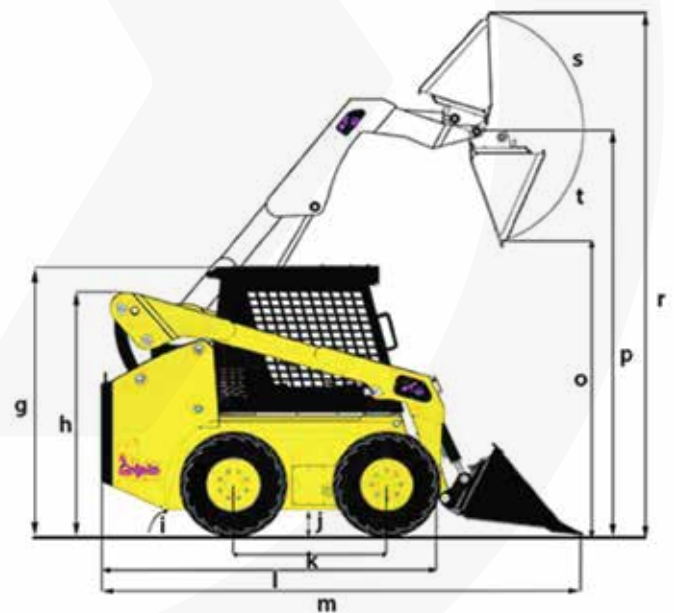

Diesel

Hydraulic System

Loading Capacity

Cab